

Li-ion

Lithium Ion Rechargeable Battery

Secondary Battery



LITHIUM ION RECHARGEABLE BATTERY

Notes for Designers

Select the correct type of battery to match the operating conditions such as load current, etc.

This brochure introduces lithium-ion cells only. Maxell offers these cells in battery pack format only, which include electronic circuits to prevent overcharge, overdischarge and so on. These battery packs are custom-developed and produced according to special requirements regarding operating conditions and specifications. As a result, a minimum number of units may apply to such customized orders from customers purchasing battery packs. For details, consult your nearest Maxell dealer or distributor.

Charge Conditions

To get the most out of lithium-ion batteries and use them safely, please read the following requirements carefully:

Charge Mode	Constant Current, Constant Voltage Charge
Charge Voltage	4.20V±0.05V / cell
Max. Charge Current	1C*
Charge Time	Approx. 3 hours*
Charge Temperature	0 to +45 deg. C

* As for cylindrical lithium ion rechargeable batteries (high-power type), please consult your Maxell representative.

Charge Control Flowchart (sample)

Refer to the following flowchart when designing constant current and constant voltage battery chargers.

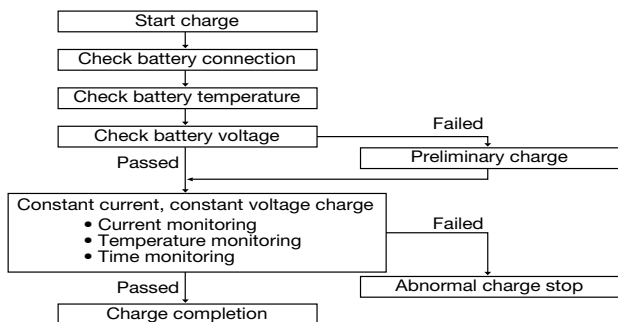

Safety Instructions

Improper use of the battery may cause heat, fire, explosion, damage or reduced battery capacity. Please read and follow the handling instructions for the battery before and during usage. The followings are general cautions and guidelines only and as such may not include every possible usage scenario. The manufacturer will not be liable for actions taken or accidents caused.

Danger

- Do not dip or wet the battery in water, seawater, or other liquid. Otherwise the battery may be shorted, which may generate heat or cause damage.
- Do not put the battery into a fire. Otherwise, the electrolyte may burn or cause an explosion.
- Do not heat the battery. Otherwise the electrolyte may boil and resin parts may melt, causing leakage, explosion or fire.
- The battery has a predetermined polarity. If the battery will not connect well to the charger or equipment, do not try to connect the battery forcefully. Check the polarity first. If the battery is connected in reverse, it will be charged in reverse and may cause leakage, heat generation, explosion or fire due to an abnormal chemical reaction.
- Do not connect the battery in reverse relation to the positive (+) and negative (-) terminals in the charger or equipment. If the battery is connected in reverse, it will be charged in reverse, discharge excessive current and may cause heat generation, explosion or fire due to an abnormal chemical reaction.
- Do not let the battery terminals (+ and -) come into contact with a wire or any metal (like a metal necklace or a hairpin) with which it is carried or stored. In such a case, the battery will be shorted and discharge excessive current, which may result in heat generation, explosion or fire.
- Do not apply any heavy impact to the battery, throw or drop it. Otherwise the battery may be shorted and result in heat generation, explosion or fire.

- Do not drive a nail into, hammer or stamp on the battery. Otherwise the battery may be shorted and result in heat generation, explosion or fire.
- Do not solder the battery directly. Heat applied during soldering may melt resin parts such as separator or gasket, and result in leakage, heat generation, explosion or fire.
- Do not disassemble or alter the battery. Otherwise the battery may be shorted and result in heat generation or fire.
- Do not use or leave the battery near fire, heaters, inside an automobile in hot weather or under strong sunshine. Such conditions of high temperature may damage the separator, and the battery may be shorted and result in heat generation, explosion or fire.
- When charging the battery, do not use any battery charger not specified by the manufacturer. Always follow the charge conditions specified by the manufacturer. If the battery is charged under other conditions (a high temperature, a high voltage/current or an altered charger) not specified by the manufacturer, the battery may cause heat generation, explosion or fire due to abnormal chemical reactions.
- Do not connect the battery directly to an electric outlet or cigarette lighter socket in a car. Applying a high voltage may generate an excessive current and cause an electric shock. In such a case, the battery may leak electrolyte, overheat, explode or cause fire.

⚠ Warnings

- Do not put the battery in a microwave oven or a pressure cooker. Sudden heat may damage the seal of the battery and may cause heat generation, explosion or fire.
- Do not use the battery together with a primary battery such as a dry battery or other battery of a different capacity, type and/or brand. In such a case, over-discharge during use or over-charge during charging may occur and abnormal chemical reactions may cause heat generation, explosion or fire from the battery.
- If you notice any unusual odor, heat, discoloration, deformation or any other characteristic apart from what you are used to while using, charging or storing the battery, then take it out of the equipment or charger, and avoid using it. Using it in such state may result in heat generation, explosion or fire.
- If the battery leaks or emits an unusual odor, remove it from the vicinity of any fire immediately. The electrolyte may catch fire, which may cause heat generation or explosion.
- Do not let leaked electrolyte come into contact with the eyes. In the event of such contact, flush the eyes with plenty of water immediately and consult a doctor. Otherwise prolonged contact may cause serious injury.

⚠ Caution

- If the battery leaks and its electrolyte comes into contact with skin or clothes, wash the contact area well with tap water or other clean water right away. Otherwise skin may break out in a rash.
- When the battery is expected not to be used for a long time, take the battery out of the equipment or device and store it in a less humid area.
- After long periods of storage without being used, the battery should be charged before it is used. Charge the battery every 6 months to the level specified by the manufacturer, even if the battery is not used.
- Do not leave the battery pack connected to the charger. It may cause the degradation of battery performance, such as a shortening of battery life.
- Turn off your equipment or device power switch after use.
- Do not use the battery in other than the following temperature ranges:

Charge	0 deg. C to +45 deg. C
Discharge	-20 deg. C to +60 deg. C
Storage (less than 30 days)	-20 deg. C to +50 deg. C
Storage (less than 90 days)	-20 deg. C to +35 deg. C

Notes for treating used batteries

- Insulate (+) and (-) terminals with tape.
- Do not remove coating.
- Do not expose to rain or water.
- Do not disassemble.
- Do not leave under strong sunshine.
- Store in rugged receptacle and cover with a lid.

Prismatic Lithium Ion Rechargeable Battery

Overview

Maxell has concentrated its original technologies accumulated during the development of various products such as magnetic tapes, IC cards and memory cards, as well as its battery technology into Maxell's lithium ion batteries. With Maxell's unique manufacturing technology and quality control system, including carefully selected electrode materials, sealing technology, and micron-order accuracy control, Maxell has developed lithium ion batteries featuring various excellent characteristics and high reliability.

Cell Structure

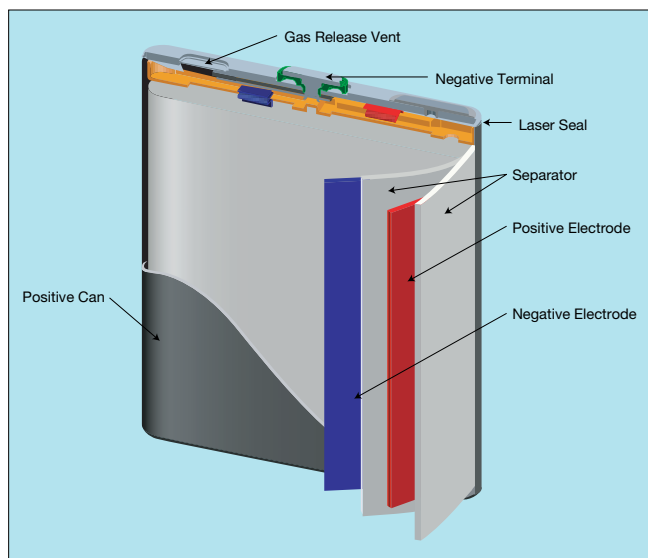

Features

■ Higher operating voltage of 3.7V and energy density

A lithium-ion battery delivers and maintains a stable operating voltage of over 3.7V until final discharge — three times as much voltage as a Ni-Cd or Ni-MH battery provides. It takes just 1/3 the number of lithium-ion batteries to provide the equivalent amount of voltage from Ni-Cd or Ni-MH batteries, so portable devices can be made much smaller and lighter.

■ Higher discharge rate for more powerful devices

Lithium-ion batteries are capable of outstanding rates of discharge sufficient to power a hard disk, a video camera's motor and other devices.

■ Stable discharge under various temperatures environmental conditions

Lithium-ion batteries provide stable discharge within a wide range of temperatures, from -20 deg. C to +60 deg. C.

■ Superior storage characteristics and convenience including minimal self-discharge

Lithium-ion batteries limit self-discharge to less than 5% of the original capacity per month when batteries are stored at 20 deg. C.

■ Excellent cost performance

Superior recharging properties ensure a service life of about 500 charge/discharge cycles under normal usage conditions. The superior cost/performance ratio ensures that lithium-ion batteries are ultimately more economical than primary batteries.

Applications

- Mobile Phones ● PHS ● PDAs ● Electronic Dictionaries
- Camcorders ● Digital Still Cameras
- Digital Audio Players ● Portable Game Devices

Characteristics (ICP553450SR)

Charge Characteristics

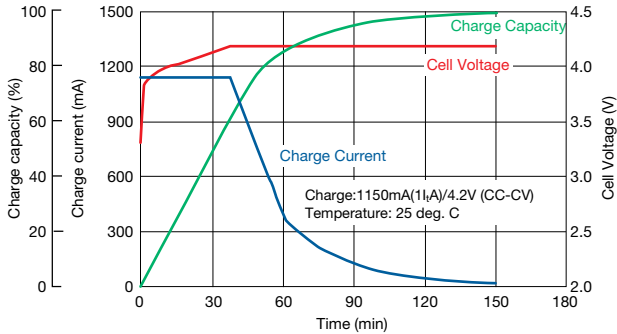

Discharge Load Characteristics

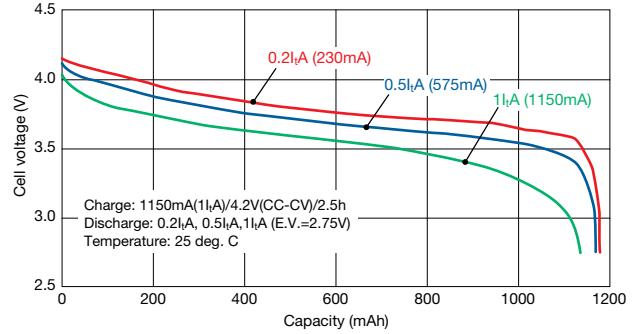

Discharge Temperature Characteristics

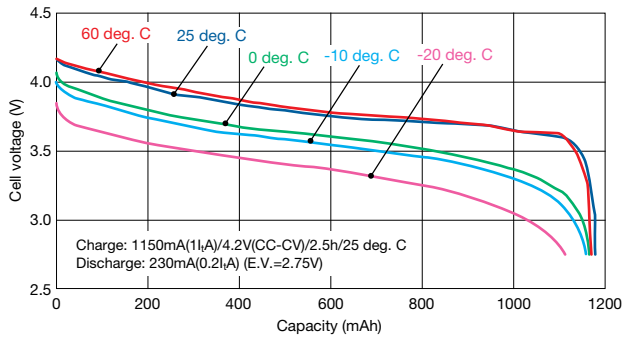

Cycle Life Characteristics

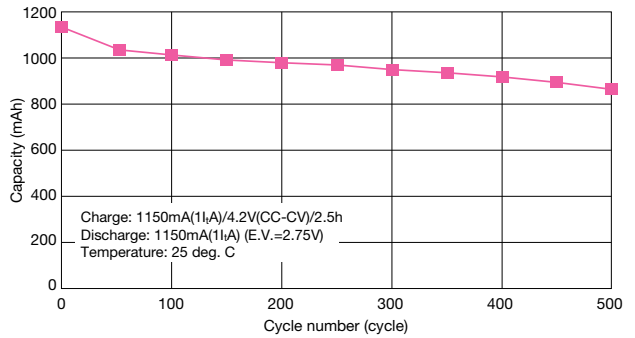

Products

Cell Type*1		ICP403450AR	ICP463443SR	ICP463446AR	ICP463450AR	ICP483640SR	ICP494261SRU	ICP533640SR	ICP553443AR
Dimensions*2 (mm)	Thickness	3.9±0.2	4.4±0.2	4.4±0.2	4.4±0.2	4.6±0.2	4.7±0.2	5.0±0.3	5.2±0.3
	Width	33.7±0.2	33.8±0.2	33.8±0.2	33.8±0.2	35.8±0.2	41.8±0.2	35.8±0.2	33.8±0.2
	Height	49.7+0/-0.5	42.95+0/-0.5	46.0+0/-0.5	49.6+0/-0.5	40.0+0/-0.5	61.0+0/-0.5*5	40.0+0/-0.5	42.8+0/-0.5
Weight (g)*3		16	15	16	18	17	29	18	18
Charge (CCCV)	Max. Voltage (V)	4.2	4.2	4.2	4.2	4.2	4.2	4.2	4.2
	Max. Current (A)	0.80	0.79	0.82	0.92	0.82	1.50	0.90	0.92
Discharge (CC)	End Voltage (V)	2.75	2.75	2.75	2.75	2.75	2.75	2.75	2.75
	Max. Current (A)	1.20	1.19	1.23	1.38	1.23	2.25	1.35	1.38
Nominal Voltage (V)		3.7	3.7	3.7	3.7	3.7	3.7	3.7	3.7
Minimum Capacity (mAh)*4		800	790	820	920	820	1500	900	920

Cell Type*1		ICP553446AR	ICP553450SR	ICP653047AS	ICP653443AR	ICP653450AR	ICP653850SRU	ICP783640SR	ICP803443AR
Dimensions*2 (mm)	Thickness	5.2±0.3	5.2±0.3	6.2±0.3	6.2±0.3	6.2±0.3	6.2±0.3	7.5±0.3	7.7±0.3
	Width	33.8±0.2	33.8±0.2	30.0±0.2	33.8±0.2	33.8±0.2	37.8±0.2	35.8±0.2	33.8±0.2
	Height	46.0+0/-0.5	49.6+0/-0.5	47.1+0/-0.5	42.6+0/-0.5	49.6+0/-0.5	50.0+0/-0.5	40.0+0/-0.5	42.6+0/-0.5
Weight (g)*3		19	21	20	21	24	28	25	25
Charge (CCCV)	Max. Voltage (V)	4.2	4.2	4.2	4.2	4.2	4.2	4.2	4.2
	Max. Current (A)	1.00	1.15	1.00	1.10	1.20	1.45	1.34	1.35
Discharge (CC)	End Voltage (V)	2.75	2.75	2.75	2.75	2.75	2.75	2.75	2.75
	Max. Current (A)	1.50	1.73	1.50	1.65	1.80	2.18	2.01	2.03
Nominal Voltage (V)		3.7	3.7	3.7	3.7	3.7	3.7	3.7	3.7
Minimum Capacity (mAh)*4		1000	1150	1000	1100	1200	1450	1340	1350

Positive electrode: Lithium cobalt dioxide, Negative electrode: Graphite

*1: "U" indicates that the cell has a Upper Positive Terminal.

*2: Dimensions of fresh cell without tube.

*3: Approximate value

*4: Capacity is according to the following conditions: Charge CCCV: 1I_t/4.2V/3h, Discharge 0.2I_t/E.V.=2.75V, Temperature 25 deg. C

*5: No positive terminal plate on the cell bottom

Above specifications are subject to change without notice. For more detailed information and availability, please consult your Maxell representative.

Cylindrical Lithium Ion Rechargeable Battery (High-power type)

NOVIL

Overview

Maxell developed high-power lithium ion rechargeable battery. We will expand the application of lithium ion rechargeable battery to high power application with its features, small and light weight.

Cell Structure

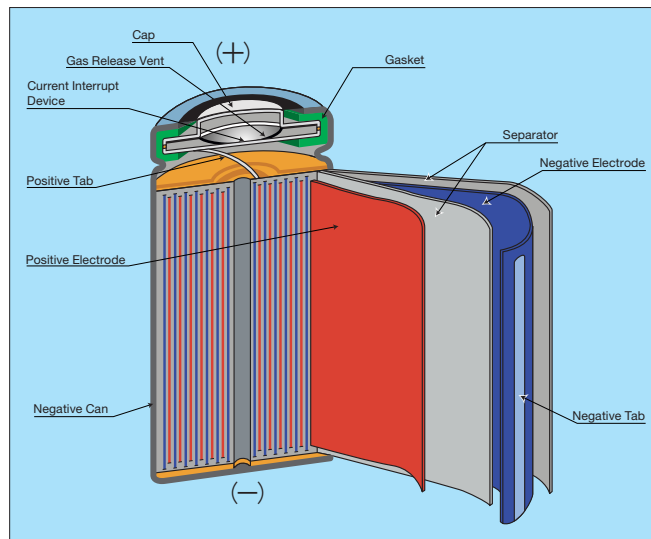

Applications

- Power Tools
- Cordless Home Appliances

Specifications are subject to change without notice. For more detailed information and availability, please consult your Maxell representative.

Characteristics (INR18650PB1)

Charge Characteristics

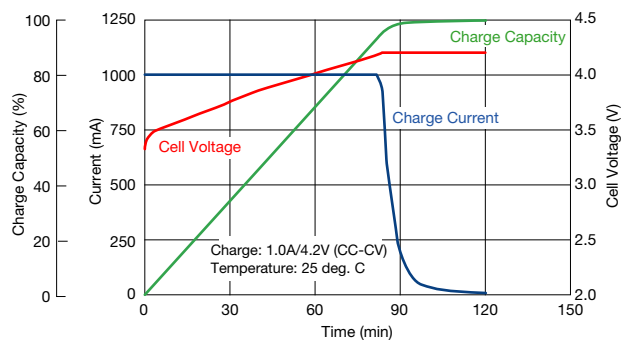

Discharge Load Characteristics

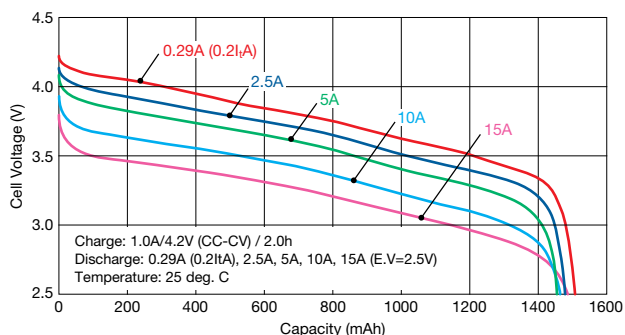

Features

Maximum output of 25 amps. (INR18650PB2)

Newly developed electrode materials and structure make it possible to get the maximum output of 25 amps. It is suitable for power tools and so on.

Superior safety and reliability

The positive electrode composition, which includes a spinel-type lithium manganese oxide that has high thermal stability, and the separator, which has minimal thermal contraction even at abnormally high temperatures, makes the battery much safer and more reliable.

Stable discharge from -20 deg. C to 60 deg. C

High-power cylindrical lithium ion rechargeable batteries provide stable discharge within a wide range of temperatures, from -20 deg. C to 60 deg. C.

Products

Model		INR18650PB1	INR18650PB2
Dimensions*1 (mm)	Diameter	18.3±0.2	18.3±0.2
	Height	64.95+0.15/-0.30	64.95+0.15/-0.30
Weight*2 (g)		41	41
Charge (CCCV)	Max. Voltage (V)	4.2	4.2
	Max. Current (A)	2.0	2.0
Discharge (CC)	End Voltage (V)	2.5	2.5
	Max. Current*3 (A)	15	25
Nominal Voltage (V)		3.7	3.7
Minimum Capacity*4 (mAh)		1450	1450

*1 Dimensions of fresh cell with tube

*2 Approximate value

*3 Please contact us about conditions of use when using battery as assembled battery.

*4 Capacity is according to the following conditions: Charge CCCV: 1A/4.2V/2h, Discharge: 0.29A/E.V.=2.5V, Temperature: 25 deg. C

Discharge Temperature Characteristics

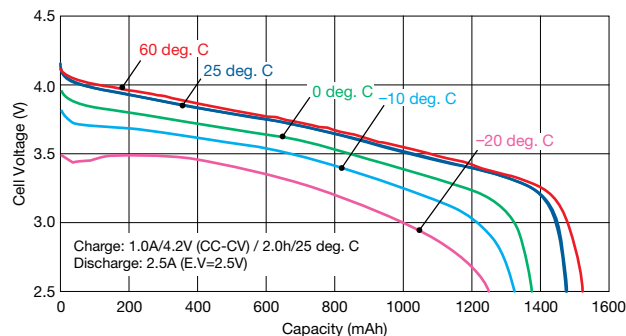

Cycle Life Characteristics

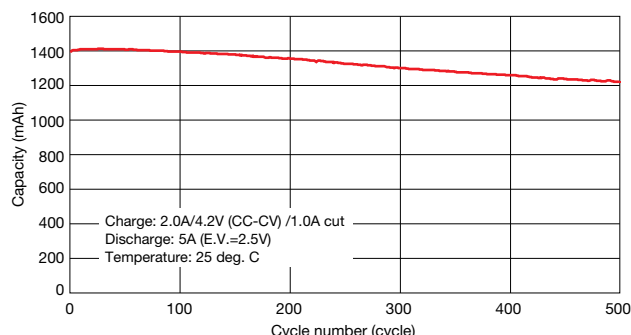

Transportation of Lithium Batteries and Lithium Ion Rechargeable Batteries

Dangerous Goods Transportation Regulations for Lithium ion cells and batteries(*)

The following transportation regulations have both recently been revised:

- International Civil Aviation Organization (ICAO) Technical Instructions (ICAO-TI)
- International Maritime Organization (IMO) International Maritime Dangerous Goods (IMDG) Code

Additional revisions have been made affecting the ICAO-TI alone, intended specifically for air transport.

Regulation	Effective date		Mandatory date
IATA/ICAO	Jan. 1, 2009		Jan. 1, 2009
IMADG Code	Jan. 1, 2009	(Transition period)	Jan. 1, 2010

It is important that necessary arrangements be made so that all those concerned are thoroughly informed of the revisions.

The minimum requirements necessary to transport as non-restricted goods are as follows;

- 1) For lithium ion cells, the Watt-hour rating is not more than 20 Wh. For lithium ion batteries, the Watt-hour rating is not more than 100 Wh. The Watt-hour rating must be marked on the outside of the battery case except for those manufactured before 1 January 2009, which may be transported without this marking until 31 December 2010.
- 2) Each cell or battery is of the type proven to meet the requirement of each test in the UN Manual of Tests and Criteria, Part III, sub-section 38.3.
- 3) A battery handling label must be displayed on each package. A telephone number must be printed on the label for additional information.
- 4) Each consignment must be accompanied by a document for transport* with an indication that:
 - the package contains lithium ion cells or batteries;
 - the package must be handled with care and that a flammability hazard exists if the package is damaged;
 - special procedure should be followed in the event the package is damaged, to include inspection and repackaging if necessary; and
 - a telephone number for additional information.

*For air transport, the words "Not Restricted" and the above information must be indicated on the Air Waybill.

- 5) Each package must be capable of withstanding a 1.2 m drop test.

Maxell will offer the certificate of 1) and 2) as the need arises. Documentation for 3) and 4) need to be prepared by the customer. If our package is used for transport, we offer the certificate for 5) as the need arises.

(*) Lithium ion cells and batteries:

Lithium ion rechargeable batteries

Prismatic Type, Cylindrical Type (High-Power Type)



Hitachi Maxell, Ltd.
2-18-2, Iidabashi,
Chiyoda-ku, Tokyo
102-8521 Japan
Tel: (+81) 3-3515-8244
Fax: (+81) 3-3515-8303

Visit our website at: www.maxell.com

NORTH AMERICA / SOUTH AMERICA

Maxell Corporation of America

Main Office:
22-08, Route 208 Fair Lawn,
NJ 07410, U.S.A.
Tel: (+1) 201-794-5900
Fax: (+1) 201-796-8790
Web Site:
<http://www.maxell-usa.com/>

Canada Branch:
237 Romina Drive, Suite 200,
Concord, Ontario L4K 4V3, Canada
Tel: (+1) 905-669-8107
Fax: (+1) 905-669-8108
E-mail: support@maxellcanada.com
Web Site:
<http://www.maxellcanada.com/>

Maxell Latin America

Plaza Btresh - Calle 50,
Panama City, Panama
Tel: (+507) 269-6737
Fax: (+507) 263-4413
E-mail: maxell@ciabtresh.com
Web Site:
<http://www.maxellpan.com/>

EUROPE

Maxell Europe Ltd.

**European Headquarters & UK
Sales Office:**
Whitebrook Park, Lower Cookham
Road, Maidenhead, Berkshire
SL6 8YA, United Kingdom
Tel: (+44) 1628-41-2100
Fax: (+44) 1628-41-2010
E-mail: hq@maxell.eu.com
(European Headquarters)
sales@maxell.eu.com
(UK Sales Office)
Web Site:
<http://www.maxell.eu.com>

Hungary Branch:
H-1097 Budapest, Mariassy utca 7,
Hungary
Tel: (+36) 1-464-3800
Fax: (+36) 1-464-3801
E-mail: mhu@maxell.eu.com

Maxell Deutschland GmbH

Mollsfeld 2, 40670 Meerbusch,
F. R. Germany
Tel: (+49) 2159-913-0
Fax: (+49) 2159-913-150
E-mail: mdg@maxell.eu.com

Maxell (France)

Parc D'Activites Du Vert Galant,
BP 97091 Saint Ouen L'Aumone,
95 052 Cergy-Pontoise Cedex, France
Tel: (+33) 1-3424-88 11
Fax: (+33) 1-3073-56 77
E-mail: mfr@maxell.fr

Maxell Italia S.p.A.

Via Dante 2, 21100 Varese, Italy
Tel: (+39) 0332-283548
Fax: (+39) 0332-288691
E-mail: info@maxell-italia.it

Maxell Spain S.A.

Balmes 89, 6-3a, 08008
Barcelona, Spain
Tel: (+34) 933-237-013
Fax: (+34) 934-517-814
E-mail: es@maxell.eu.com

ASIA

Maxell Asia, Ltd.

Main Office:
506, World Commerce Centre,
Harbour City, Phase 1, Canton
Road, Kowloon, Hong Kong
Tel: (+852) 2730-9243
Fax: (+852) 2735-6250
E-mail: maxell@maxell.com.hk
Web Site:
<http://www.maxell.com.hk/>

Vietnam Office:
Room No. 15, Mezzanine Floor,
Sun Wah Tower, 115 Nguyen Hue
Boulevard, District 1, Ho Chi Minh
City, Vietnam
Tel: (+84) 8-821-9183
Fax: (+84) 8-821-9181
E-mail: maxellvn@saigonnet.vn

Maxell (Shanghai) Trading Co., Ltd.

Main Office:
PLAZA 336, Room No. 1801, 18th
Floor, No. 336, Xi Zang Middle
Road, Huang Pu District, Shanghai,
200001, China
Tel: (+86) 21-3330-3377
Fax: (+86) 21-3330-4001
E-mail: maxell@maxell.net.cn
Web Site:
<http://www.maxell.com.cn/>

Beijing Office:
Room 905, C Wantong Tower, No.6
Chaowai Road, Chaoyang District,
Beijing 100020, China
Tel: (+86) 10-5907-0016
Fax: (+86) 10-5907-0017
E-mail: maxellbj@public.bta.net.cn

Guangzhou Office:
Room 1203, Victory Plaza Tower B,
103-1 Tiyu West Road, Guangzhou
510620, China
Tel: (+86) 20-3839-3834
Fax: (+86) 20-8527-7353

Maxell Taiwan, Ltd.

14F, No. 111, Sung Chiang Road,
Taipei 104, Taiwan
Tel: (+886) 2-2516-5553
Fax: (+886) 2-2516-4804
E-mail: maxell@maxell.com.tw
Web Site:
<http://www.maxell.com.tw/>

Maxell Asia (Singapore) Pte. Ltd.

Main Office:
10 Anson Road, #25-06, International
Plaza, Singapore 079903
Tel: (+65) 6220-9291
Fax: (+65) 6220-6070
E-mail: sales@maxell.com.sg
Web Site:
<http://www.maxell.com.sg/>

Chennai Office:
DBS Office Business Center, 31A,
Cathedral Garden Road, Near
Palmgrove Hotel, Chennai-600 034,
Tamil Nadu, India
Tel: (+91) 44-5264-9495
Fax: (+91) 44-5264-9495
E-mail:
maxellchennai@touchtelindia.net

Mumbai Office:
No. 401, 4th Floor Banarasi Heritage,
Mind Space, Link Road, Malad
(West), Mumbai-400 064, India
Tel: (+91) 22-3212-8193
Fax: (+91) 22-4003-0585